

www.cl-light.com

SHENZHEN CL LIGHTING TECHNOLOGY CO.,LTD

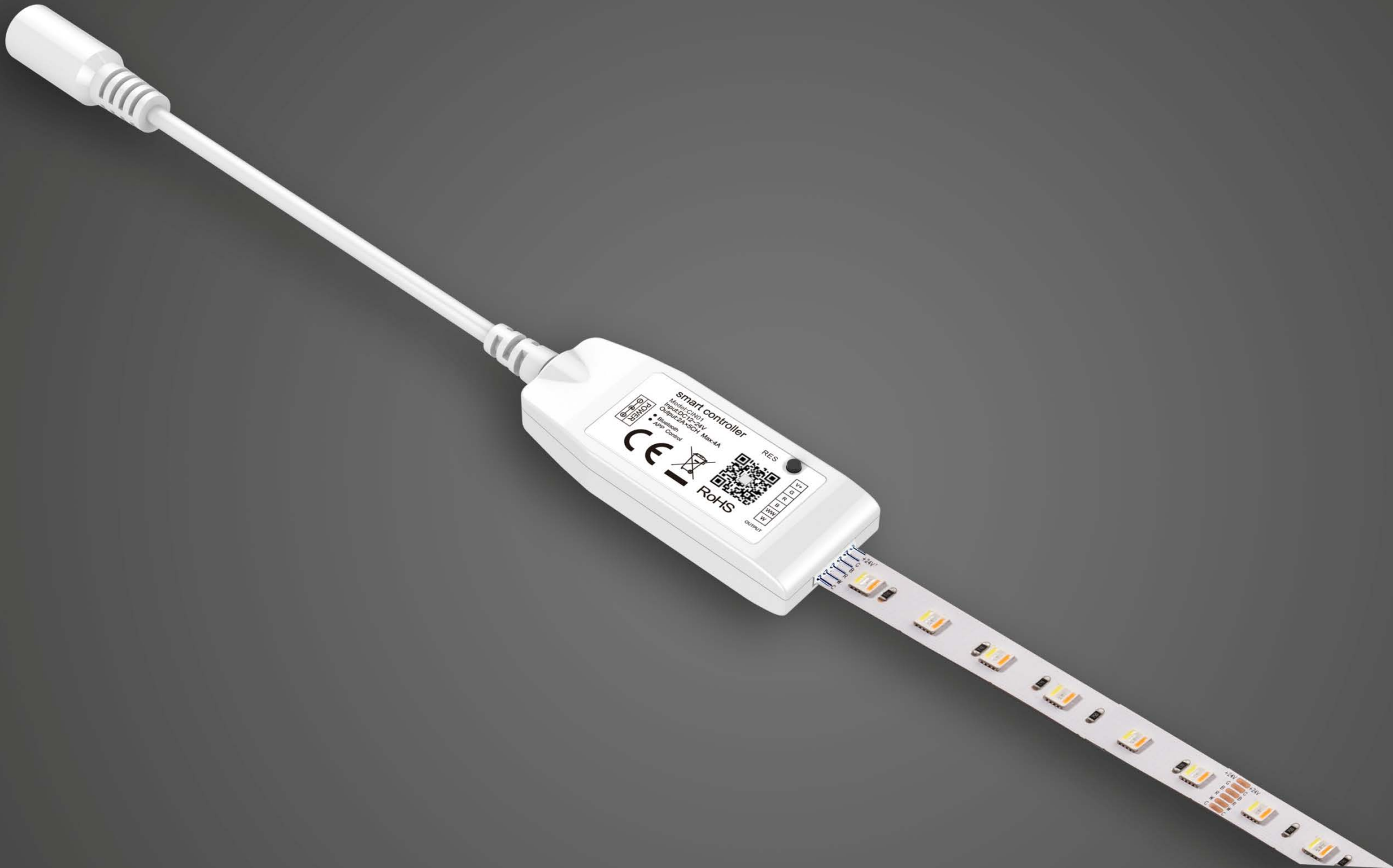

**LED Smart  
Controller**



smart controller  
Model: S1001  
Input: DC12V/2A  
Output: 2A/5CH Max=4A  
Bluetooth  
App Control

RES

CE

RoHS

QR Code

Output

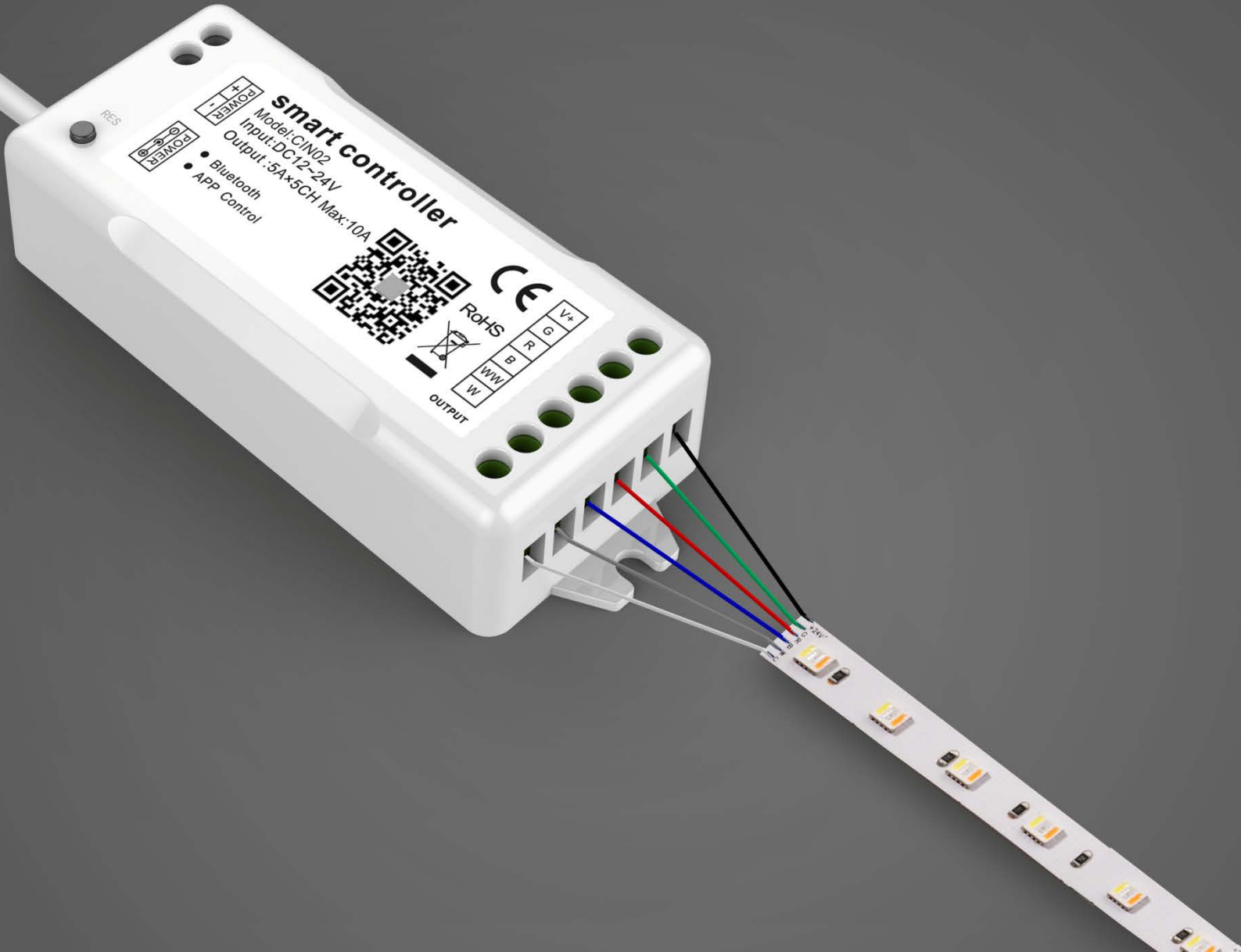

POWER  
RES  
POWER  
RES

**smart controller**  
Model: CJN02  
Input: DC 12~24V  
Output: 5A\*5CH Max: 10A  
• Bluetooth  
• APP Control



RoHS

V+  
G  
R  
B  
W  
W

OUTPUT

24V

# APP Bluetooth Control



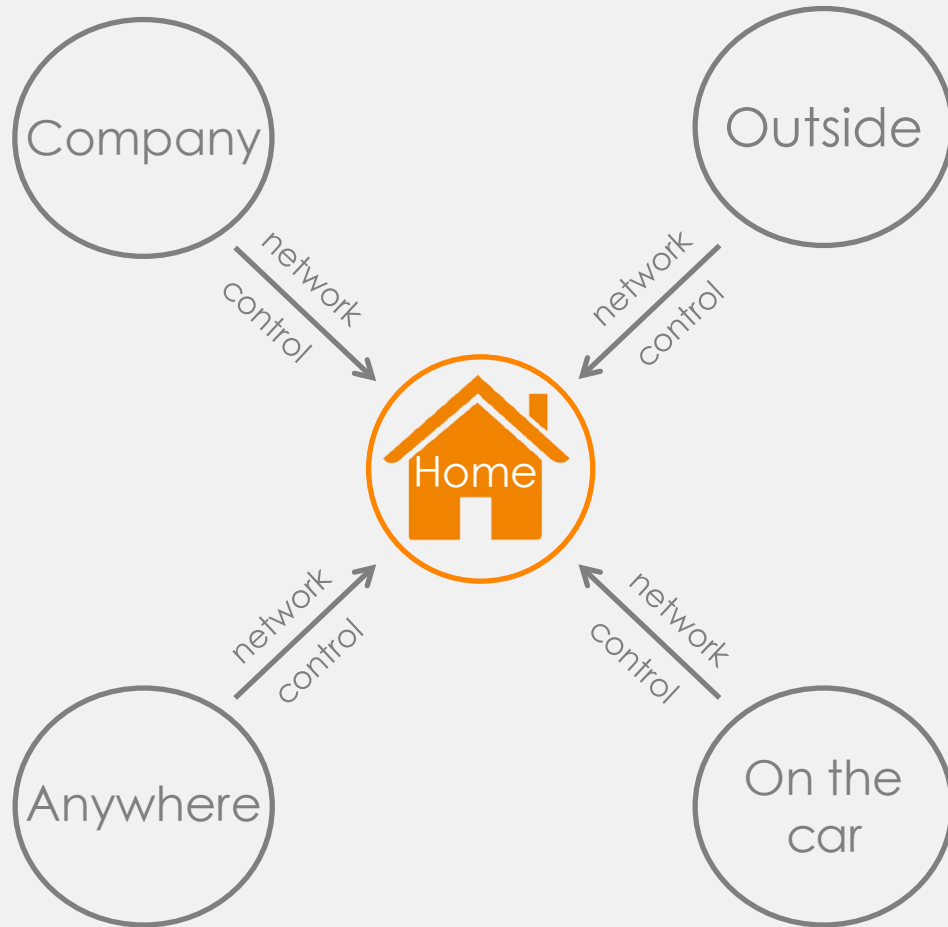

## Long Range Control with Gateway

---

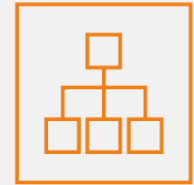

---

Connecting Internet via APP,  
controlled regardless of distance,  
time, location

# Amazon Echo Voice Control

---



---

Smart voice control, support English language



Amazon Echo



Small Genie





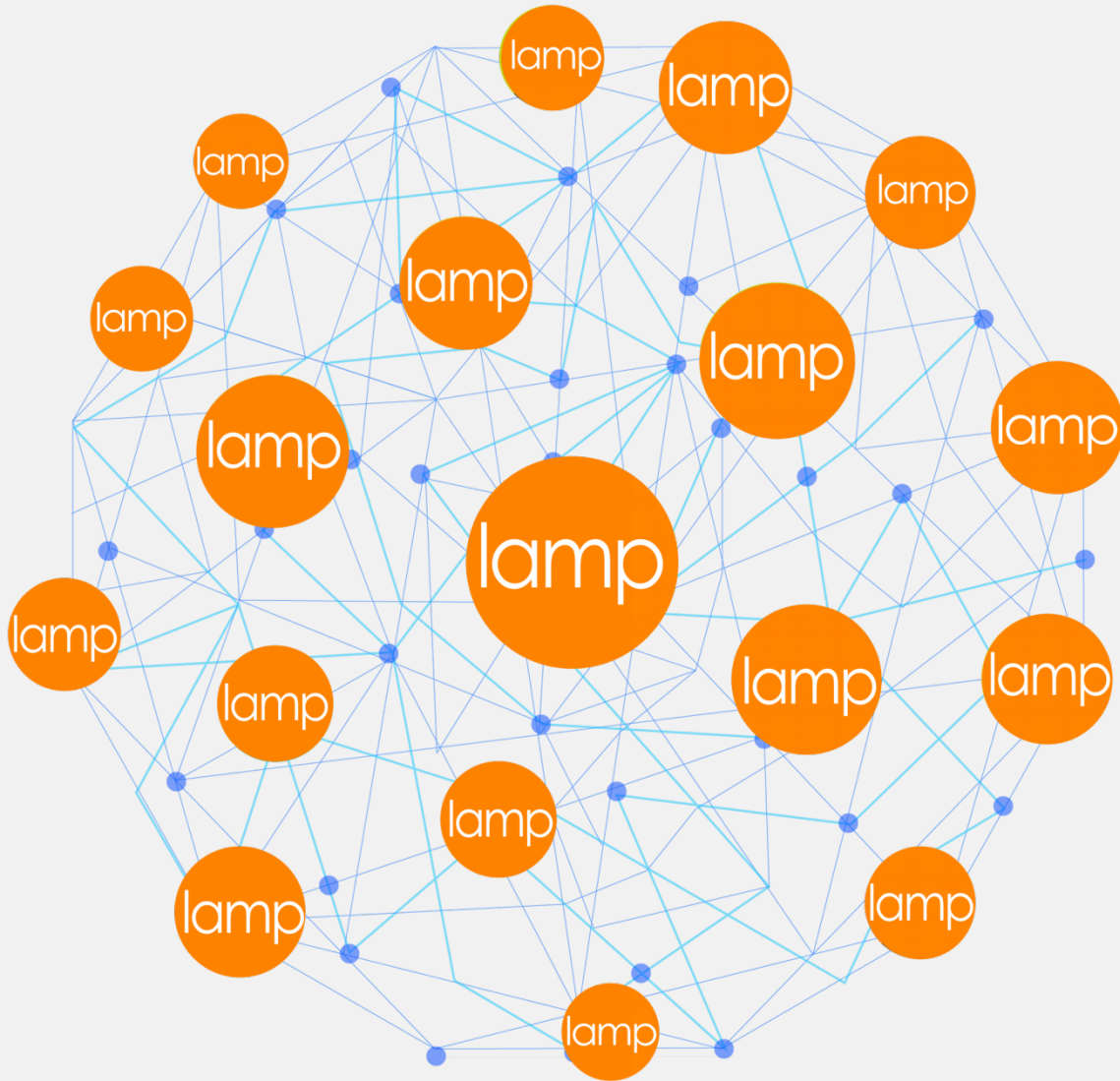

Supports more than 6,000  
fixture connections

---



---

Ideal for applications in large public places



## Group control and management

---



Convenient with group control and management of all lamps, creating a comfortable and warm atmosphere.



## Realize Unified Control of Different Lights

---



---

Lights are not limited to one type, achieve unified control if used lights are match with controller.

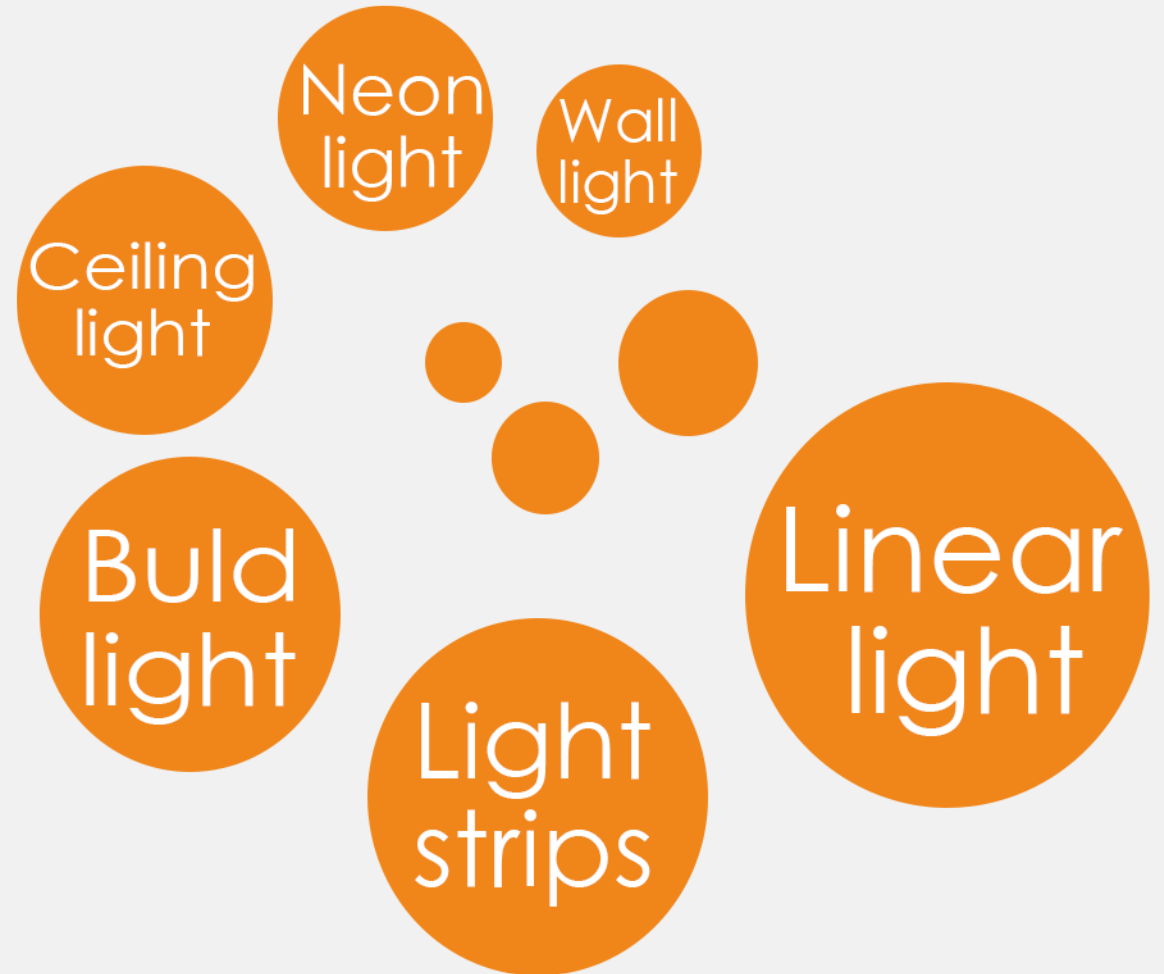

## Support multi-user control at the same time

---



---

It can support multiple users to control through the APP at the same time, rather than only one user can control through the APP.

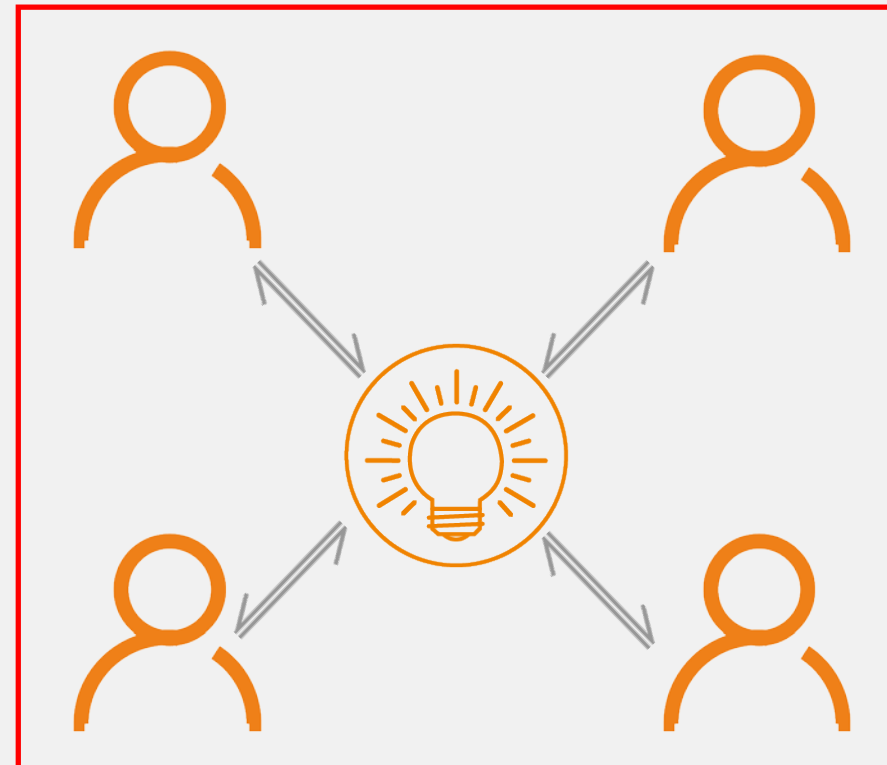

# Applications



▲ Office



◀ Hotel Lobby



Living Room ▶



# Applications

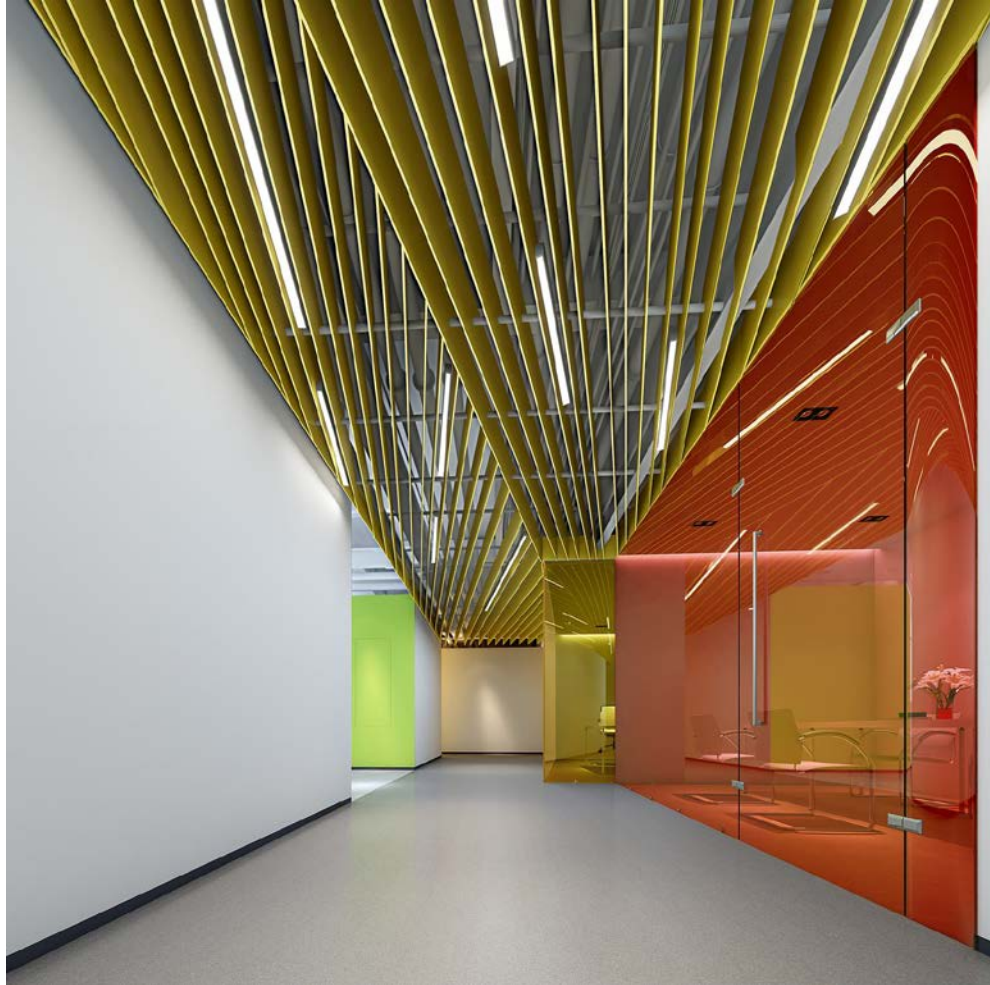

▲ Public Places

Exhibition Hall ▶



◀ Living Room

# MINI Controller

## Parameters

- Input Voltage: 12V~24Vdc
- Power: Max.96W
- Current: 2A/CH Max.4A
- Wireless :Bluetooth 4.0
- G.W.: 25g
- Dimension: 58x23x10mm
- Working temperature: -20°C~45°C

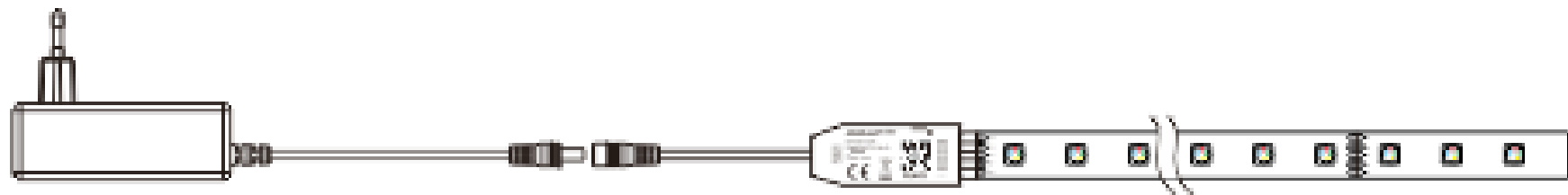
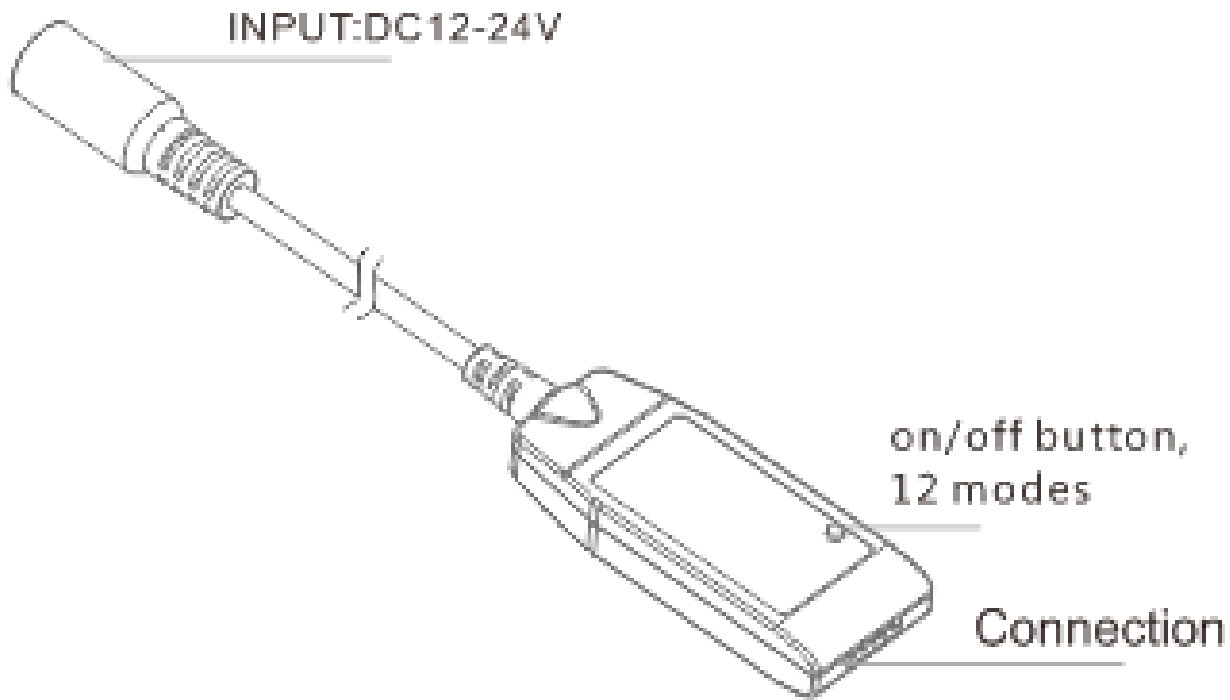



# HIGH Controller

## Parameters

Input Voltage: 12V~24Vdc  
Power: Max.240W  
Current: 4A/CH Max.10A  
Wireless :Bluetooth 4.0  
G.W.: 50g  
Dimension: 85.5x39x21.3mm  
Working temperature: -20°C~45°C

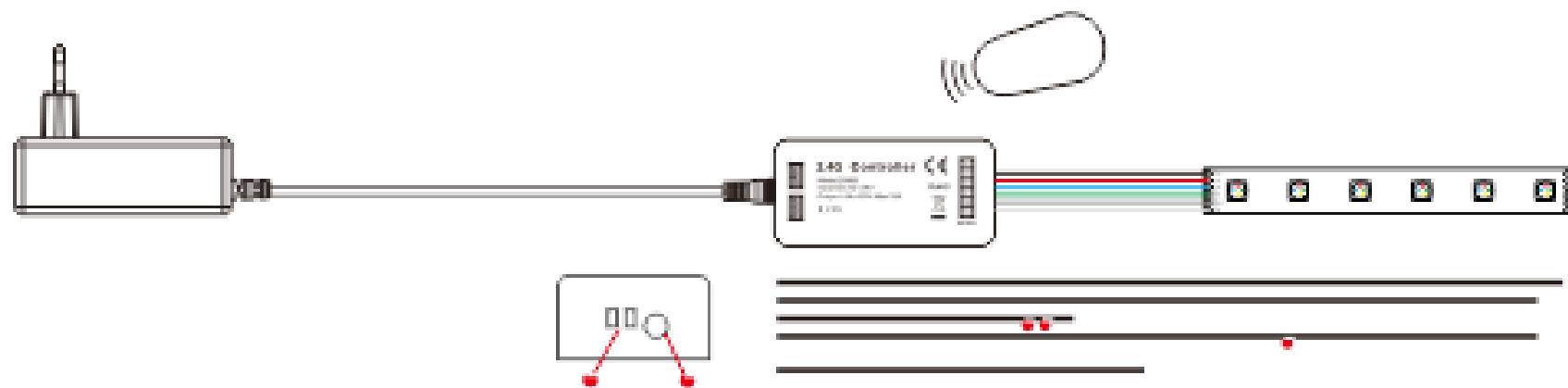
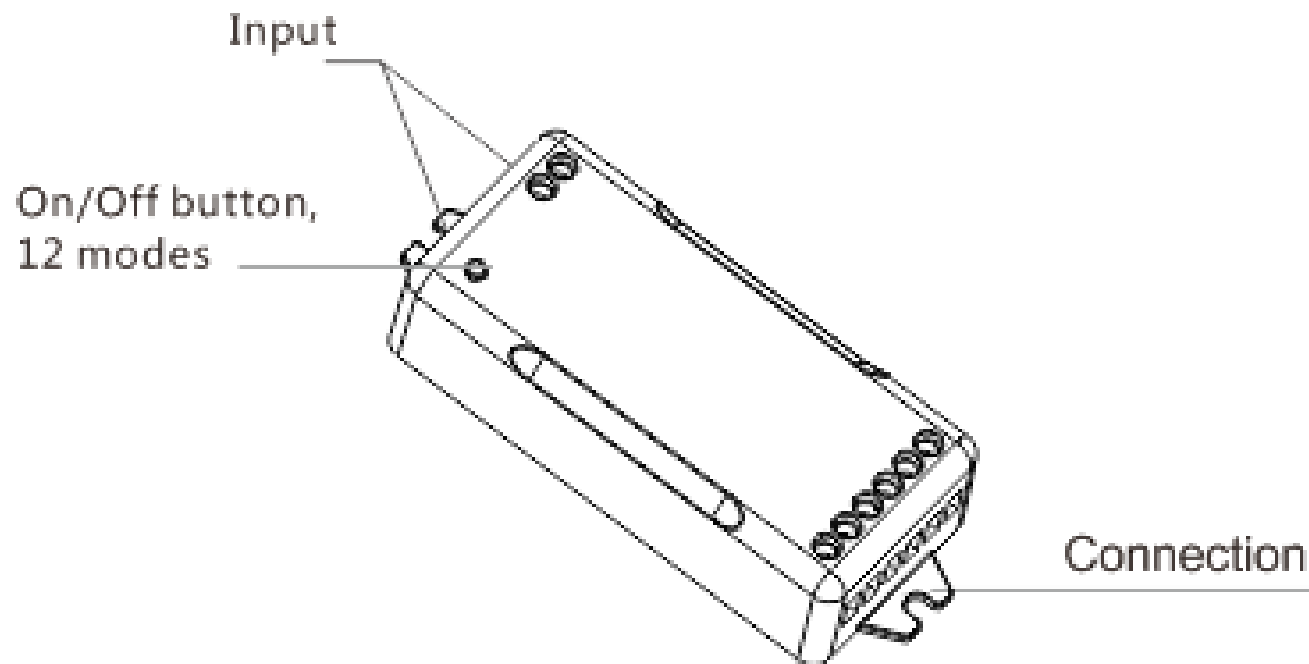

# Suit

## Blister and box





---

For more information about our smart low voltage LED series or any other CL Lighting product, please get in touch:

 +86-755-27643784 | 36959611

 +86-755-27655433

 cl@banqcn.com

 www.cl-light.com

---

SHENZHEN CL LIGHTING TECHNOLOGY CO.,LTD

Address: Building A&B, 3th industrial Zone, Shiyan Town, Bao'an District, ShenZhen, China